

# CHRISTMAS TREE KIT

MODEL K-14

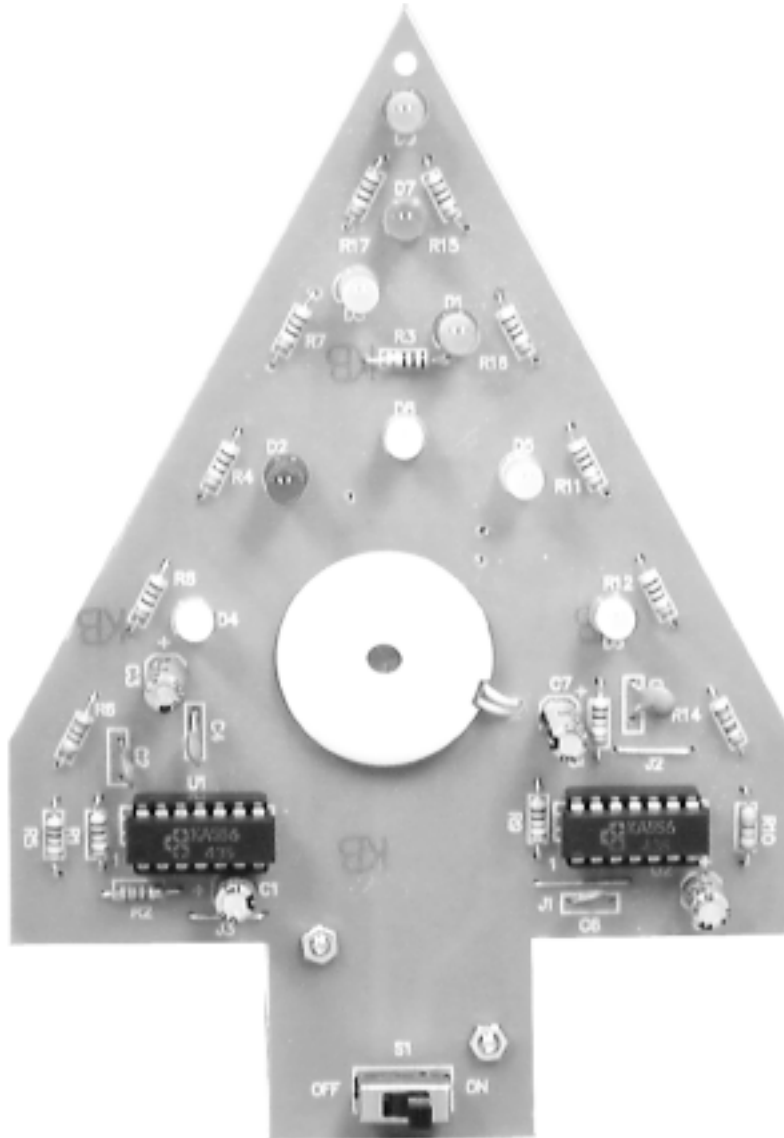

7 56619 00006 0



Assembly and Instruction Manual

## Elenco™ Electronics, Inc.

# PARTS LIST

If you are a student, and any parts are missing or damaged, please see instructor or bookstore.

If you purchased this kit from a distributor, catalog, etc., please contact Elenco™ Electronics (address/phone/e-mail is at the back of this manual) for additional assistance, if needed. **DO NOT** contact your place of purchase as they will not be able to help you.

## RESISTORS

| Qty.                       | Symbol                          | Value         | Color Code                | Part # |
|----------------------------|---------------------------------|---------------|---------------------------|--------|
| <input type="checkbox"/> 9 | R3, 4, 7, 8, 11, 12, 15, 16, 17 | 1.2kΩ 5% 1/4W | brown-red-red-gold        | 141200 |
| <input type="checkbox"/> 4 | R1, R5, R9, R13                 | 10kΩ 5% 1/4W  | brown-black-orange-gold   | 151000 |
| <input type="checkbox"/> 1 | R14                             | 33kΩ 5% 1/4W  | orange-orange-orange-gold | 153300 |
| <input type="checkbox"/> 1 | R10                             | 47kΩ 5% 1/4W  | yellow-violet-orange-gold | 154700 |
| <input type="checkbox"/> 1 | R6                              | 56kΩ 5% 1/4W  | green-blue-orange-gold    | 155600 |
| <input type="checkbox"/> 1 | R2                              | 68kΩ 5% 1/4W  | blue-gray-orange-gold     | 156800 |

## CAPACITORS

| Qty.                       | Symbol         | Value       | Description          | Part # |
|----------------------------|----------------|-------------|----------------------|--------|
| <input type="checkbox"/> 4 | C2, C4, C6, C8 | .01μF (103) | Discap               | 241031 |
| <input type="checkbox"/> 4 | C1, C3, C5, C7 | 10μF        | Electrolytic (Lytic) | 271045 |

## SEMICONDUCTORS

| Qty.                       | Symbol     | Value   | Description            | Part # |
|----------------------------|------------|---------|------------------------|--------|
| <input type="checkbox"/> 2 | U1, U2     | (LM556) | 556 Integrated Circuit | 330556 |
| <input type="checkbox"/> 3 | D1, D2, D9 |         | LED Red                | 350002 |
| <input type="checkbox"/> 3 | D6, D7, D8 |         | LED Green              | 350010 |
| <input type="checkbox"/> 3 | D3, D4, D5 |         | LED Yellow             | 350020 |
| <input type="checkbox"/> 1 | U3         |         | PC Board 3 Melody      | 510004 |

## MISCELLANEOUS

| Qty.                         | Symbol | Description                | Part # |
|------------------------------|--------|----------------------------|--------|
| <input type="checkbox"/> 1   |        | PC Board                   | 518031 |
| <input type="checkbox"/> 1   | SW1    | Switch                     | 541022 |
| <input type="checkbox"/> 24" |        | Solder Roll                | 551135 |
| <input type="checkbox"/> 1   | B1     | Battery Holder             | 590096 |
| <input type="checkbox"/> 1   |        | Buzzer with Wires          | 595202 |
| <input type="checkbox"/> 2   |        | Screw 2-56 x 5/16" Slotted | 641231 |
| <input type="checkbox"/> 2   |        | Nut 2-56 Hex Zinc          | 644201 |
| <input type="checkbox"/> 2   |        | IC Socket 14-pin           | 664014 |

## IDENTIFYING RESISTOR VALUES

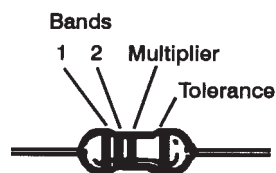

| BAND 1<br>1st Digit |       | BAND 2<br>2nd Digit |       | Multiplier |            | Resistance<br>Tolerance |           |
|---------------------|-------|---------------------|-------|------------|------------|-------------------------|-----------|
| Color               | Digit | Color               | Digit | Color      | Multiplier | Color                   | Tolerance |
| Black               | 0     | Black               | 0     | Black      | 1          | Silver                  | +10%      |
| Brown               | 1     | Brown               | 1     | Brown      | 10         | Gold                    | +5%       |
| Red                 | 2     | Red                 | 2     | Red        | 100        | Brown                   | +1%       |
| Orange              | 3     | Orange              | 3     | Orange     | 1,000      | Red                     | +2%       |
| Yellow              | 4     | Yellow              | 4     | Yellow     | 10,000     | Orange                  | +3%       |
| Green               | 5     | Green               | 5     | Green      | 100,000    | Green                   | +5%       |
| Blue                | 6     | Blue                | 6     | Blue       | 1,000,000  | Blue                    | +25%      |
| Violet              | 7     | Violet              | 7     | Silver     | 0.01       | Violet                  | +1%       |
| Gray                | 8     | Gray                | 8     | Gold       | 0.1        |                         |           |
| White               | 9     | White               | 9     |            |            |                         |           |

## PARTS IDENTIFICATION

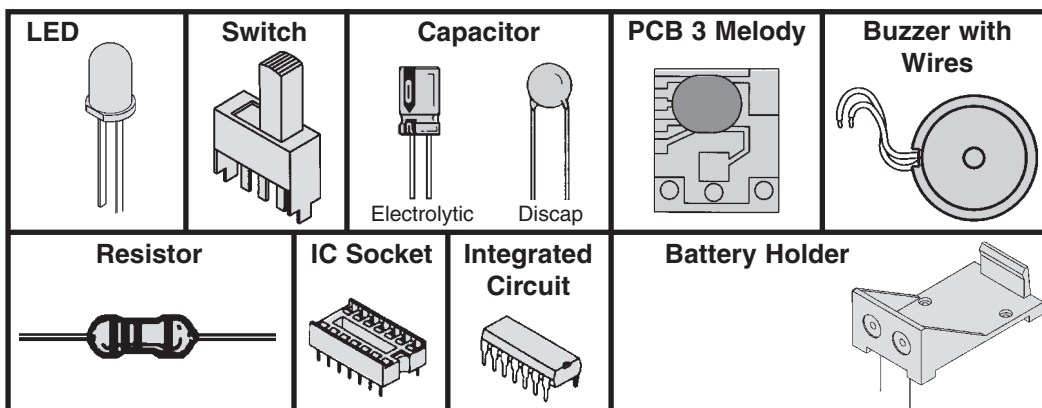

# INTRODUCTION

The Electronic Christmas Tree Kit is a fun project which also gives you the opportunity to learn about the wonderful field of electronics. The heart of the Electronic Christmas Tree is a 556 integrated circuit. This chip contains two 555 timers which are very popular in the electronic circuit blocks. The sound of the Electronic Christmas Tree is a special integrated circuit with a piezoelectric buzzer. You'll enjoy three charming Christmas melodies: Jingle Bells, Santa Claus is Coming to Town, and We Wish You a Merry Christmas.

# CIRCUIT OPERATION

The 556 timer uses two 555 ICs. Since the Electronic Christmas Tree Kit contains two 556 timers, there are a total of four 555 timers used in our circuit. We will confine our analysis to the 555 circuit. The pinout of the 555 is shown in Figure 1.

The basic circuit of the 555 timer as used in the Electronic Christmas Tree Kit as shown in Figure 2. This circuit is used four times with a slight variation of components. Refer to the schematic diagram on page 6 to get a better idea of the total circuit.

The 555 operates in the astable or clock mode. This means that the IC puts out a series of pulses or oscillations as shown in Figure 3. These pulses are at the output pin 3, and go high and low in voltage. Note that when the output goes high, LED D2 will light since there will be about nine volts across R4 and D2. When the output goes low, LED D1 will light. Thus, the two LEDs will alternately be ON at the rate determined by the frequency of the oscillator. This frequency is controlled by the values of capacitor C1 and resistors R1 and R2. This combination is called an RC time constant. This determines the time constants, the lower the frequency of oscillation. Thus, if you make the capacitor C1 or resistors R1 and R2 larger in value, the LEDs will take a longer time to flip ON and OFF.

Resistors R1 and R2 determine the duty cycle of the output square wave. The current charging capacitor C1 goes through resistors R1 and R2. At this time, LED D2 will be lit. At a certain charge level the IC will react and start discharging C1. The discharge current will flow only through resistor R2. At this time, LED D1 will be lit. The difference in charge and discharge time will change the shape of the square wave as shown in Figure 4.

LED D2 will light a little longer than LED D1. Having the LEDs ON for slightly different time intervals adds to the flashing effects.

To review what we've learned, the values of R1, R2 and C1 determine the output frequency or how fast the LEDs flash. The relationship between R1 and R2 determines the duty cycle or how long LED D1 will be lit in comparison with LED D2.

The other three 555 timers operate the same except for different values for R2. Resistors R6, R10 and R14 are each made higher in value, thus each timer will oscillate at a slightly higher frequency. The blinking rate will be different for each timer. Capacitors C2, C4, C6 and C8 are added to stabilize the circuit.

The sound circuit of the Christmas Tree Kit is shown in Figure 5. U3 is a special integrated circuit. Its memory has three Christmas melodies. These melodies will repeat all of the time when the switch (S1) is in the ON position. IC U3 needs to have a power supply of 1.5 - 2V, the same drop voltage as the LEDs. The piezoelectric buzzer utilizes the principle that crystal material vibrates when an electric current is imposed upon it.

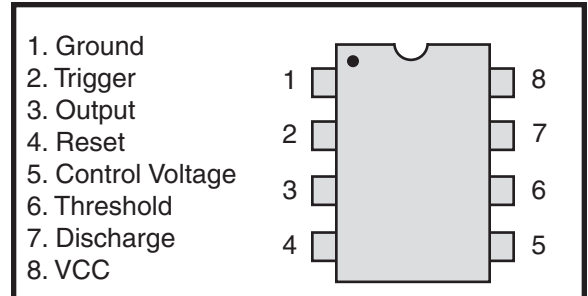

Figure 1

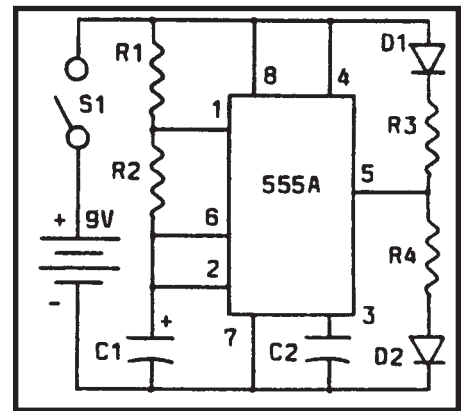

Figure 2

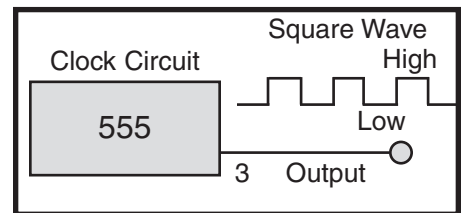

Figure 3

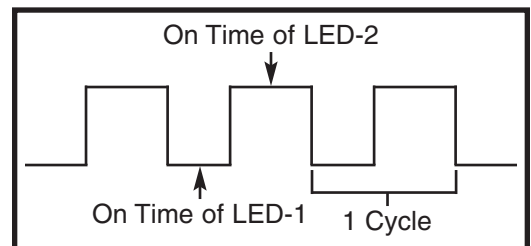

Figure 4

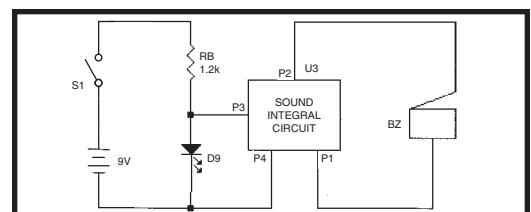

Figure 5

# CONSTRUCTION

## Introduction

The most important factor in assembling your K-14 Electronic Christmas Tree Kit is good soldering techniques. Using the proper soldering iron is of prime importance. A small pencil type soldering iron of 25 - 40 watts is recommended. **The tip of the iron must be kept clean at all times and well tinned.**

## Safety Procedures

- Wear eye protection when soldering.
- Locate soldering iron in an area where you do not have to go around it or reach over it.
- **Do not hold solder in your mouth.** Solder contains lead and is a toxic substance. Wash your hands thoroughly after handling solder.
- Be sure that there is adequate ventilation present.

## Assemble Components

In all of the following assembly steps, the components must be installed on the top side of the PC board unless otherwise indicated. The top legend shows where each component goes. The leads pass through the corresponding holes in the board and are soldered on the foil side.

**Use only rosin core solder of 63/37 alloy.**

**DO NOT USE ACID CORE SOLDER!**

## What Good Soldering Looks Like

A good solder connection should be bright, shiny, smooth, and uniformly flowed over all surfaces.

1. Solder all components from the copper foil side only. Push the soldering iron tip against both the lead and the circuit board foil.

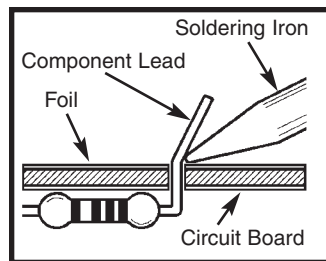

2. Apply a small amount of solder to the iron tip. This allows the heat to leave the iron and onto the foil. Immediately apply solder to the opposite side of the connection, away from the iron. Allow the heated component and the circuit foil to melt the solder.

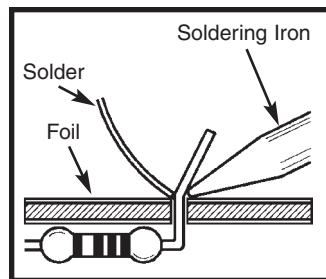

3. Allow the solder to flow around the connection. Then, remove the solder and the iron and let the connection cool. The solder should have flowed smoothly and not lump around the wire lead.

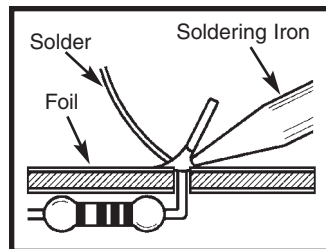

4. Here is what a good solder connection looks like.

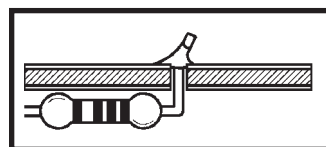

## Types of Poor Soldering Connections

1. **Insufficient heat** - the solder will not flow onto the lead as shown.

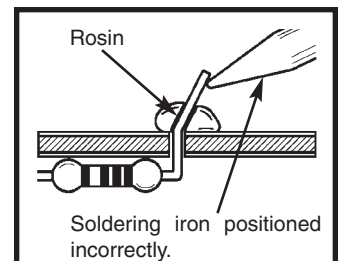

2. **Insufficient solder** - let the solder flow over the connection until it is covered. Use just enough solder to cover the connection.

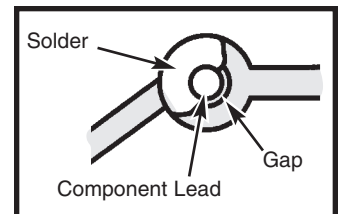

3. **Excessive solder** - could make connections that you did not intend to between adjacent foil areas or terminals.

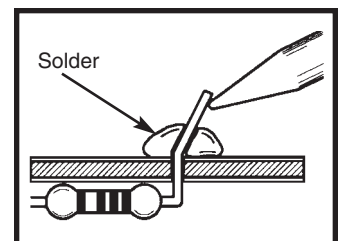

4. **Solder bridges** - occur when solder runs between circuit paths and creates a short circuit. This is usually caused by using too much solder. To correct this, simply drag your soldering iron across the solder bridge as shown.

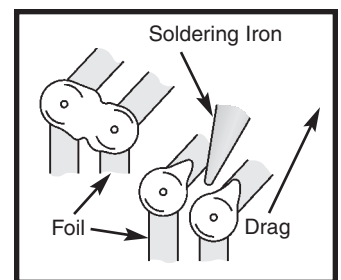

# ASSEMBLE COMPONENTS TO THE PC BOARD

- D9 - Red LED  
(see Figure A)
- R17 - 1.2k $\Omega$  5% 1/4W Resistor  
(brown-red-red-gold)
- D3 - Yellow LED  
(see Figure A)
- R7 - 1.2k $\Omega$  5% 1/4W Resistor  
(brown-red-red-gold)
- D2 - Red LED  
(see Figure A)
- R4 - 1.2k $\Omega$  5% 1/4W Resistor  
(brown-red-red-gold)
- D4 - Yellow LED  
(see Figure A)
- R8 - 1.2k $\Omega$  5% 1/4W Resistor  
(brown-red-red-gold)
- C3 - 10 $\mu$ F Electrolytic Cap.  
(see Figure B)
- R6 - 56k $\Omega$  5% 1/4W Resistor  
(green-blue-orange-gold)
- C2 - .01 $\mu$ F (103) Capacitor
- R1 - 10k $\Omega$  5% 1/4W Resistor  
 R5 - 10k $\Omega$  5% 1/4W Resistor  
(brown-black-orange-gold)
- R2 - 68k $\Omega$  5% 1/4W Resistor  
(blue-gray-orange-gold)
- 14-pin IC Socket  
 U1 - 556 Integrated Circuit  
(see Figure C)
- J3 - Jumper Wire  
(see Figure D)
- C1 - 10 $\mu$ F Electrolytic Cap.  
(see Figure B)
- C4 - .01 $\mu$ F (103) Capacitor
- S1 - Slide Switch  
(Cut off excess leads.)

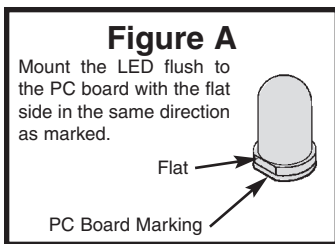

- R15 - 1.2k $\Omega$  5% 1/4W Resistor  
(brown-red-red-gold)
- D7 - Green LED
- D1 - Red LED  
(see Figure A)
- R16 - 1.2k $\Omega$  5% 1/4W Resistor  
 R3 - 1.2k $\Omega$  5% 1/4W Resistor  
(brown-red-red-gold)
- D8 - Green LED  
 D5 - Yellow LED  
(see Figure A)
- R11 - 1.2k $\Omega$  5% 1/4W Resistor  
(brown-red-red-gold)
- D6 - Green LED  
(see Figure A)
- R12 - 1.2k $\Omega$  5% 1/4W Resistor  
(brown-red-red-gold)
- C8 - .01 $\mu$ F (103) Discap
- R14 - 33k $\Omega$  5% 1/4W Resistor  
(orange-orange-orange-gold)
- J2 - Jumper Wire  
(see Figure D)
- R10 - 47k $\Omega$  5% 1/4W Resistor  
(yellow-violet-orange-gold)
- 14-pin IC Socket  
 U2 - 556 Integrated Circuit  
(see Figure C)
- C5 - 10 $\mu$ F Electrolytic Cap.  
(see Figure B)
- C6 - .01 $\mu$ F (103) Discap
- J1 - Jumper Wire  
(see Figure D)
- R9 - 10k $\Omega$  5% 1/4W Resistor  
 R13 - 10k $\Omega$  5% 1/4W Resistor  
(brown-black-orange-gold)
- C7 - 10 $\mu$ F Electrolytic Cap.  
(see Figure B)

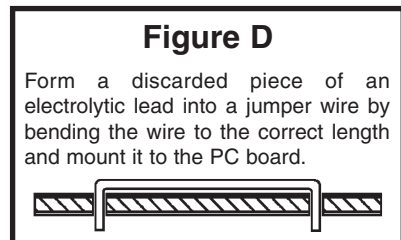
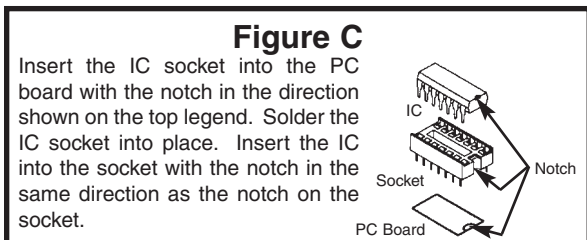
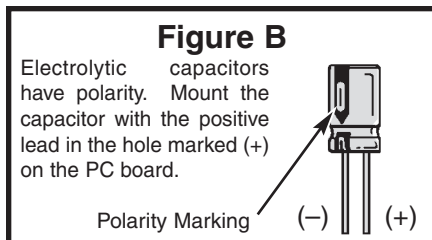
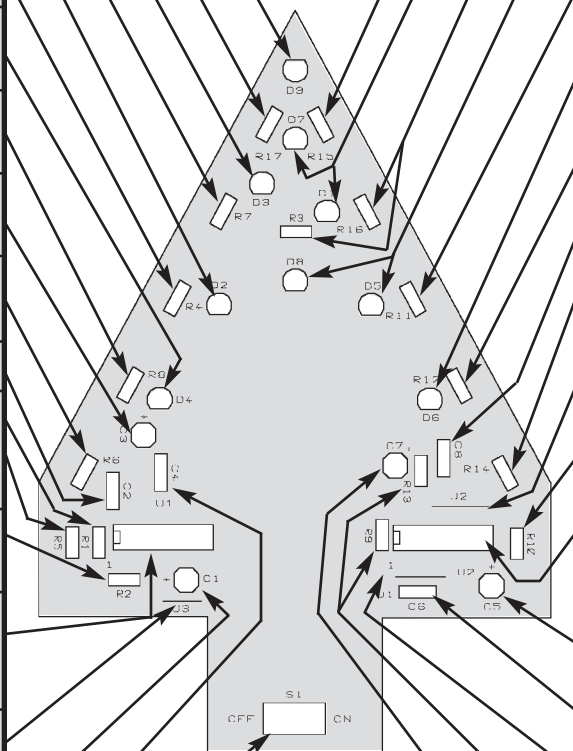

## SOUND CIRCUIT INSTALLATION

1. Thread the buzzer wires through the hole (near C7) from the component side of the PC board as shown in Figure E.
2. Solder the wire from the outer edge of the buzzer to the point -BZ on the PC board. Solder the wire from the inner circle of the buzzer to point +BZ on the PC board as shown in Figures E and F.
3. Use a piece of Scotch Tape and secure the buzzer to the component side of the PC board as shown in Figure E.
4. Use two small pieces of Scotch Tape and secure the three melody PC board to the solder side of the main PC board as shown in Figure F.
5. Using discarded component leads, solder four jumper wires to the four points on the three melody PC board. Then solder the wires to the four points on the main PC board as shown in Figure F.

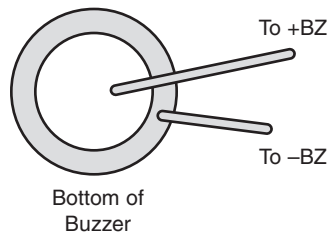

**Figure E**

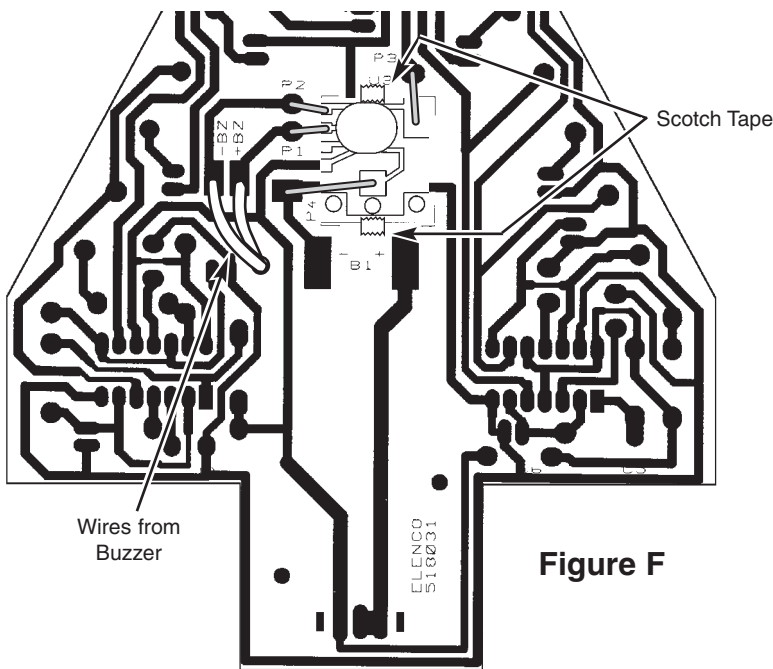
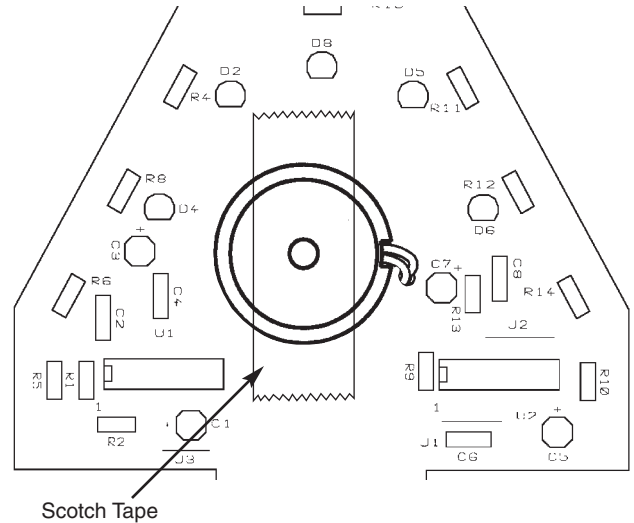

**Figure F**

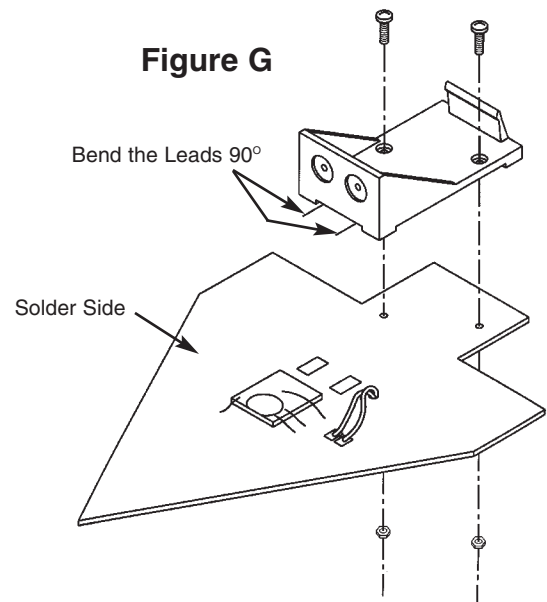
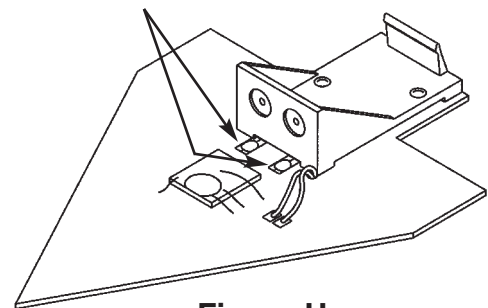

**Figure G**

## BATTERY HOLDER INSTALLATION

1. Bend the leads of the holder 90° as shown in Figure G.
2. Use two screws and two nuts to mount the battery holder to the solder side of the PC board.
3. Solder the negative (-) battery holder lead to the "-" pad on the PCB. Solder the positive (+) battery holder lead to the "+" pad on the PCB.
4. Put a 9V alkaline battery into the holder.

Solder Battery Holder Leads to These Pads



**Figure H**

# OPERATING INSTRUCTIONS

Turn the switch on. The LEDs will randomly blink and the three melodies will begin to play.

# TROUBLESHOOTING

Contact Elenco™ Electronics if you have any problems. **DO NOT** contact your place of purchase as they will not be able to help you.

1. One of the most frequently occurring problems is poor solder connections.
  - a) Tug slightly on all parts to make sure that they are indeed soldered.
  - b) All solder connections should be shiny. Resolder any that are not.
  - c) Solder should flow into a smooth puddle rather than a round ball. Resolder any connection that has formed into a ball.
  - d) Have any solder bridges formed? A solder bridge may occur if you accidentally touch an adjacent foil by using too much solder or by dragging the soldering iron across adjacent foils. Break the bridge with your soldering iron.
2. Be sure that all components have been mounted in their correct places.
  - a) Use a fresh 9 volt battery.
  - b) Be sure that the electrolytic capacitors C1, C3, C5 and C7 have been installed correctly. These capacitors have polarity, the negative and positive leads must be in the correct holes, as shown on the top legend of the PC board.
  - c) Be sure that the two 556 ICs have been installed correctly. The notch or dot on the IC should be in the same direction as shown on the top legend of the PC board.
  - d) Be sure that the LED has been installed correctly. The flat side of the LED should be in the same direction as marked on the top legend of the PC board.

# SCHEMATIC DIAGRAM

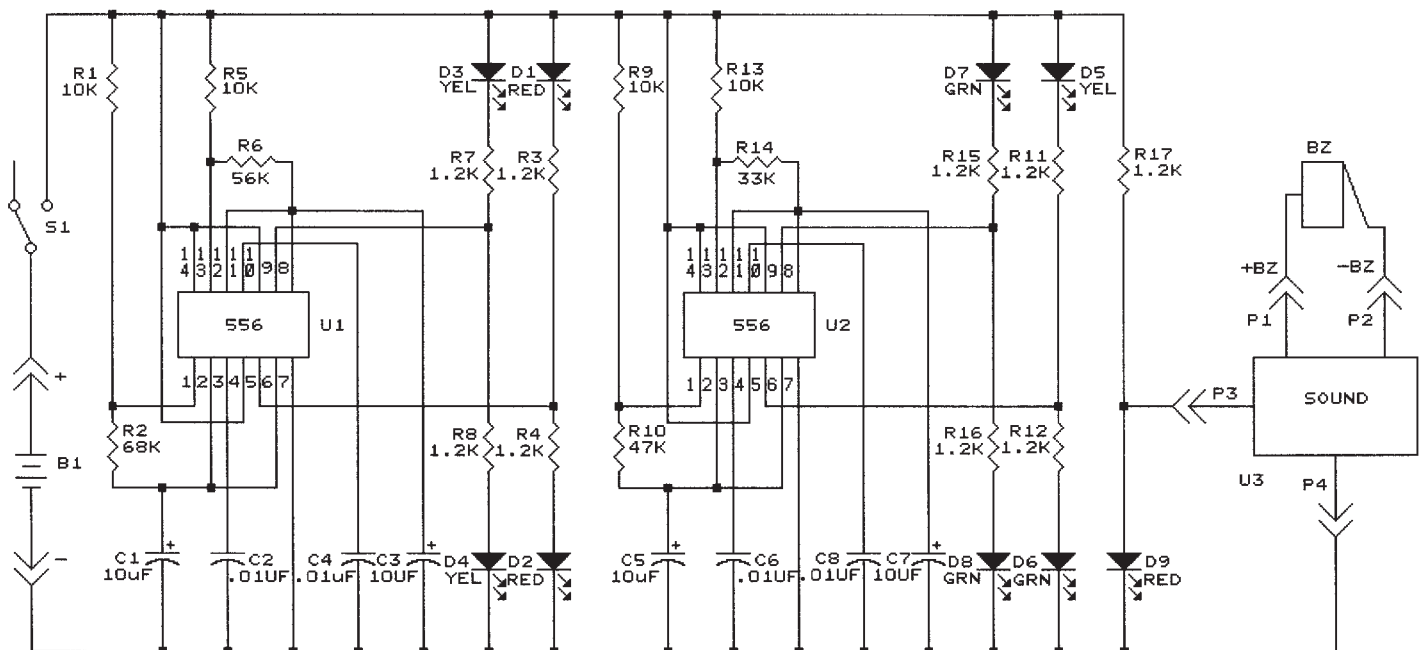

---

## QUIZ

1. The main component of the Electronic Christmas Tree is the \_\_\_\_\_ IC.
2. There are \_\_\_\_\_ 555 timers used in our circuit.
3. The LED lights when \_\_\_\_\_ appear across the LED and its resistor.
4. When the output of the 555 IC is high, the \_\_\_\_\_ LEDs will light.
5. When LED D2 is lit, LED D1 is \_\_\_\_\_.
6. Lowering the value of R2 will \_\_\_\_\_ the time that the LEDs will be ON.
7. The frequency of oscillation is determined by the values of R1, R2 and \_\_\_\_\_.
8. The duty cycle is determined by the values of R2 and \_\_\_\_\_.
9. The combinations of R1, R2 and C1 is called an RC \_\_\_\_\_ constant.
10. Capacitor C2 is added to \_\_\_\_\_ the circuit.

**Answers:** 1. 556; 2. four; 3. 9V; 4. green; 5. off; 6. decrease; 7. C1; 8. R1; 9. time; 10. stabilize

### **Elenco™ Electronics, Inc.**

150 W. Carpenter Avenue

Wheeling, IL 60090

(847) 541-3800

<http://www.elenco.com>

e-mail: [elenco@elenco.com](mailto:elenco@elenco.com)